

Reprinted from

Symposium on

Machine Processing of

Remotely Sensed Data

June 3 - 5, 1975

The Laboratory for Applications of
Remote Sensing

Purdue University
West Lafayette
Indiana

IEEE Catalog No.
75CH1009-0 -C

Copyright © 1975 IEEE
The Institute of Electrical and Electronics Engineers, Inc.

Copyright © 2004 IEEE. This material is provided with permission of the IEEE. Such permission of the IEEE does not in any way imply IEEE endorsement of any of the products or services of the Purdue Research Foundation/University. Internal or personal use of this material is permitted. However, permission to reprint/republish this material for advertising or promotional purposes or for creating new collective works for resale or redistribution must be obtained from the IEEE by writing to pubs-permissions@ieee.org.

By choosing to view this document, you agree to all provisions of the copyright laws protecting it.

AN ACQUISITION AND PROCESSING EQUIPMENT FOR SR AND VHRR
PICTURE DATA OF WEATHER SATELLITES OF THE NOAA 3 TYPE
SYMPOSIUM ON "MACHINE PROCESSING OF REMOTELY SENSED DATA,"

June 3-5, 1975.

WEST LAFAYETTE, INDIANA

R. Buecklein, E. Krauth, M. Mozer and R. Stoiber

Deutsche Forschungs- und Versuchsanstalt für
Luft- und Raumfahrt e.V.
Institut für Satellitenelektronik
8031 Oberpfaffenhofen, West-Germany

I. ABSTRACT

For meteorological research a picture processing equipment was built up to handle picture data from scanning radiometers on board the weather satellites of the NOAA 3 type. The received analog signals are digitized and stored on computer compatible tapes for processing by a computer. Simultaneously the data are fed to a picture-printer to get quick-look pictures. The picture-printer is an opto-mechanical scanner of high precision, the rotation of the film-drum of this device is synchronized with the rotation of the scanning mirrors on board the satellite. As well pictures of the scanning radiometer system (SR) as pictures of the very high resolution scanning radiometer-system (VHRR) can be printed with the same film-writer. This device also can be controlled by the data-processor to print the processed picture data. Supplementary an interactive TV-monitor-system provides the possibility for semi-automatic picture data processing.

II. INTRODUCTION

The picture processing equipment was developed under contract of the Meteorological Institute of the Free University of Berlin for processing data obtained by weather satellites equipped with scanning radiometers. On board the satellites of the NOAA 3 type two radiometer-systems are used for scanning the earth from horizon to horizon. Both systems are sensitive in two channels: in the visible range ($0.5 \mu\text{m}$ - $0.7 \mu\text{m}$) and in the thermal infrared window of the atmosphere ($10.5 \mu\text{m}$ - $12.5 \mu\text{m}$), but they distinguish in regard to their ground resolution. The SR-system has a resolution of 4 km in the visible channel and of 7.5 km in the infrared channel with respect to the subsatellite point. The ground resolution of the VHRR-system is for both channels approximately 0.9 km. The picture processing equipment was developed for processing both the SR-data and the VHRR-data in regard to:

- print scaled weather pictures in a selectable geographical projection
- present quick-look-prints of selected satellite orbits
- display cloud movements on a TV-monitor as a closed-loop recording
- operate an interactive monitor system.

III. THE PICTURE PROCESSING EQUIPMENT

Figure 1 gives a general view of the equipment which is described in details in the following sections. To support the processor, four data-acquisition systems are available which are working independent from each other: two separate data-acquisition systems are used for the acquisition of the SR- and VHRR-data to transfer these data to the processor, two other systems are used to transfer the data via a core-memory to the picture-printer for on-line recordings.

THE DATA-ACQUISITION

The analog picture signals of the IR-channel and the VIS-channel and additional informations inserted into the scan-lines are composed on board the satellite to a time-multiplexed signal during the scan-period of 1250 ms of the SR-system and 150 ms of the VHRR-system, respectively (1). In the normal transmission mode, these time-multiplexed signals as demonstrated in Fig. 2 (VHRR-signal) and Fig. 3 (SR-signal) are transmitted. After demodulation, these signals are sampled and digitized with a resolution of 8 bits/sample by the data acquisition systems.

Acquisition-System for Digital Data-Processing

The picture-data acquisition system for digital data processing is shown in Fig. 4. The sample-rate of the analog picture-signals depends on the structure of the scan-lines. The strictest requirements are given by the so-called sub-synch-markers, inserted into the VHRR-scan-lines (see Fig. 2). These markers are representing important position information in regard to the scanning system aboard the spacecraft. With respect to these sub-synch-markers the sample-rate for sampling VHRR-signals must be very high, the signals are sampled in time-intervals of 10 μ s (100 kHz). In the scan-period of 150 ms therefore 15 000 samples are obtained, containing not only the picture information of the visible channel but also of the infrared channel and the respective additional information. The SR-data are handled in the same way simultaneously to the VHRR-data handling, the sample-rate, however, is only 4 000 samples/s. So the SR-data directly can be transferred to the processor, while this is not possible for the VHRR-data because of the great amount of incoming data. Therefore, the VHRR-data are recorded as PCM-signals by a broadband instrumentation tape recorder which can store the data of at least 14 orbits. To transfer the recorded data to the processor the play-back speed of the recorder is reduced to a quarter of the recording speed.

The data-frames - according to the sample-rate of 15 000 samples/scan-line, the data frame for processing the VHRR-picture data comprises 15 000 words, each to 8 bits resolution and additional informations consisting in 48 bits. This additional informations are: local time (9 bits for days, 5 bits for hours, 6 bits for minutes and 6 bits for seconds), indication of the temporary relation between the line-synchronization-pulse and the last full second with a resolution of 50 μ s (15 bits), indication of the temporary relation between the line-synchronization-pulse and the following sample-pulse in steps of 0.417 μ s (5 bits) and finally indication whether the scan-line synchronization was detected or not (2 bits). The line-synchronization pulses are derived from the precursor signals, inserted into the scan-lines. (In the case of VHRR signals: 18.75 kHz square wave signal at the beginning of the IR-channel; 12.5 kHz signal at the beginning of the VIS-channel, demonstrated in Fig. 2. The precursor at the beginning of the SR-scan-line is a 300 Hz square-wave signal).

The data-frame for processing the SR-data is compiled analogous. In regard to the scan-line period of 1250 ms and to the sample-rate of 4000 samples/s the data frame comprises 5000 words with a 8 bits resolution and the same 48 bits additional information as described above. With respect to the low sample frequency of 4000 Hz, the temporary relation between the line-synchronization-pulse and the following sample-pulse is indicated in steps of 8.3 μ s, which gives a sufficient accuracy.

Acquisition-System for On-Line Picture Printing

For the acquisition of the VHRR-data the analog signals are sampled with respect to the sub-synch-markers with a sample-rate of 100 kHz and digitized with a resolution of 8 bits/sample, as described before. The data frames, however, contain no additional informations as it is necessary for machine-processing. The digitized picture- and control data of each four successive scan-lines are buffered in a core memory before these data are transferred to the film-writer. The core-memory contains 8 192 memory locations of 18 bits each per printed circuit card, addressable byte by byte. For each scan-line 15 000 samples are to be stored as 8-bit words. Therefore four circuit cards are necessary with collectively 32 768 addressable memory locations of 18 bits or 2 bytes, controlled by a single address-register. The block-diagram of the acquisition systems for the VHRR- and SR-data including the core-memory is shown in Fig. 5.

It is demanded to record as well the VHRR-pictures as the SR-pictures by using the same picture-printer. Therefore the sample-rate for the SR-data was defined to 12 000 samples/s. Regarding the duration of the SR scan-lines which is 1 250 ms, there results a number of 15 000 samples/scan-line which is equal to the number of samples/scan-line obtained by sampling the VHRR-signals. As either VHRR-pictures or SR-pictures are to be printed, the same core memory is used to buffer four successive scan-lines of SR picture data before the recording. The data buffer is needed for the equalization of differences between the rotation speed of the scan-mirrors of the radiometers and the film-drum of the opto-mechanical scanner. Also signal propagation delay time effects between the satellite and the ground station by transmitting the data are compensated with the aid of this memory (2). Another reason to use the data-buffer is given by the incomplete utilization of the film. The data must be transferred to the picture-printer about 9 % faster than the data transmission of the radiometer.

In particular, the core-memory is managed as follows: The data acquisition system (Fig.1) produces the synchronization pulses which are marking the beginnings of the scan-lines when they are recorded on the film-drum of the picture printer. The positive going leading edges of these marking pulses succeedingly are setting an address-counter which is controlling the writing of the picture signals into the memory, to the numbers: 0, 8192, 16834, 24576, and then beginning again with 0, and so on. So, the sampled succeeding scan lines byte by byte are read into the memory locations with the ranges 0 - 7499, 8192 - 15691, 16384 - 23883, 24576 - 32075, and then begins the next cycle again with 0 - 7499, and so on. In the case of impairing quality of the picture signals at the input-side of the digital data processing equipment to derive the marking pulses, the synchronization of the scan-lines is achieved due to the known orbit data of the satellite by the aid of the computer if there was made only once a sure external synchronization. If also this possibility disappears then the synchronization is replaced by an internal pulse sequence derived from the clock frequency of the digital image processing equipment. As a combination of these kinds of line synchronizations, the computer controlled synchronization is triggered by the satellite-controlled synchronization at each ensured external synchronization.

THE PICTURE-DATA PROCESSOR

The data-frames provided from the data acquisition systems are transferred to the processor via two direct memory access (DMA)-channels. Two central processor units are available with 16 K and 48 K core memory, respectively, connected by an interprocessor buffer system. Each processor can as well accept as distribute data by the DMA-devices. So the data transfer from the acquisition system to the processor is possible even in the case that one of the processors breaks down. Each CPU controls two magnetic tape devices. So SR-data of at least 5 satellite orbits can be stored. Moreover it was demanded to record the data received at nighttime automatically on tape. With an orbit time of the satellite of about 115 minutes this means that the data of 5 orbits with an average receiving time of 20 minutes must be recorded automatically. (The picture processor unit see Fig. 6). The picture data, stored on the computer compatible magnetic tapes (CCT's) are processed to eliminate distortions and to analyse the transmitted weather pictures with the help of the methods of image processing. To present the pictures in an usual geometric projection, mapping processes are to be accomplished. For mapping, the geometric distortions caused by variations of the sensor-platform and by the scanning process must be eliminated. Because the mirror of the radiometer is rotating at a constant angular velocity, the geometric resolution on the ground changes

as the distance from the subsatellite point increases. So in the area of the horizons, foreshortened pictures appear. The knowledge of the orbit data of the satellite gives a relation of the position of the scanned picture elements to their normal position. Because a fine-resolution time code and the deviation of the first sample from the beginning of the scan-line is indicated in the data-frame, the momentary position of the spacecraft and the scanning mirror is known for every sampled picture element. So, the distortions of the image caused by the scanning process and the position variations of the scanning system can be eliminated. This is the presupposition for mapping the earth surface in an exact scale and a desired projection. By using the picture processor as a front-end computer the elimination of the distortions must be done by a big processor-system with regard to the lot of data at least in the case of the VHRR signals received during each satellite orbit. But it is planned to extend the image processing equipment to a hybrid processor system. This special purpose computer should do the task of the rectification. For this case an analog computer will be controlled by a digital processor which stores the mathematical relations as time functions. After processing, the data are transferred to the picture-printer and are displayed at the monitor.

ON-LINE PICTURE PRINTING

Simultaneously to the machine processing of the received picture-data, the signal series are recorded in on-line either for the SR-system or the VHRR-system by an opto-mechanical scanner in the form of a hard-copy onto a black-and-white film. For automatic operation the data of two satellite orbits of collectively 16 can be preprogrammed to be recorded onto 1 hard-copy. Thereby as well SR- as VHRR-signals can be chosen. The start/stop-orders for recordings are given either automatically by the receiving device or by the operator.

The Opto-Mechanical Scanner

The picture-print device called "Chromagraph C 286" is normally used as printer for the graphic arts, its resolution is specified to 60 lines/mm (1525 lines/inch) by the manufacturer. This device was modified to be controlled by satellite-signals or by the processor, respectively. The film-drum of this scanner has a perimeter of 370 mm (14.5 inch), but only 338.75 mm (13.3 inch) are applicable, the rest is needed to stretch the film. A shaft angle encoder with a resolution of 4096 steps on the perimeter was mounted which can be connected with the axis of the film-drum by a clutch to indicate the beginning of the scan-lines and to generate clock-pulses to transfer the data from the memory to the film-writer. Furthermore the position of the pixels in every scan-line is fixed by a linear-measure with a resolution of 5 μ m which was mounted to indicate the axial movement of the scanner. Both position values are indicated by an optical display. With respect to computer controlled applications of the drum-writer the absolute values of the positions - indicated as well by the shaft angle encoder as by the linear measure - can be transferred into the computer.

Handling of the Picture-Data

The on-line picture prints are useful to give a synoptical survey of the actual weather conditions. On-line recordings of the SR-data are possible with the aid of automatic picture printers as used in "Automatic Picture Transmission Stations". Picture-prints obtained by the APT-stations are demonstrating, that the beginnings of the scan-lines are situated on a bended line, recordings of the VHRR-data by using modified APT-stations show this effect very significant (see Fig. 7). These distortions are caused by propagation delay effects for the received signals resulting from distance variations between the ground station and the satellite in orbit while the film-drum of the recording device is rotating with a constant angular velocity. To compensate the signal propagation delay effects, the scan-lines are stored in a buffer memory, furthermore the rotation speed of the film-drum and the rotation-rate of the scanning mirror of the radiometer must be synchronized. The read-out process of the picture data from the core memory and their recording onto the film drum is controlled by a special address counter. This counter is set subsequently to the numbers 0, 8192, 16384, 24576, and again beginning from 0 and so on, by a line start-signal produced by the shaft angle encoder. The incrementation of this address counter as well as the reading out of the picture signals from the core memory is successively controlled by a clock signal of

109 226.66 Hz designating the positioning of the picture elements along the scan-lines with the help of the shaft angle encoder.

The core memory system is organized in a way that the reading-out of all 32768 core locations - which are addressed by a single counter - is realized with the help of the same read-out system, i.e. the same wiring system. The same is true in regard to the clear-write processes. Therefore, the read-out and clear-write processes must be controlled in each single case that no temporal coincidence is possible. The data processing is handled so that the read-out processes provided with a clock frequency of 109226.66 Hz have priority, i.e. each read-out clock transfers information from the core memory after a D/A conversion onto the film drum.

On the other hand, there is the sampling process of the video signals coming continuously from the receiver during the satellite's contact. This process is not temporary correlated with the clock delivered by the shaft angle encoder. Therefore the sampled and digitized signals are stored during a short time in a small solid-state buffer memory to be transferred to the core memory during the temporary gaps between read-restore processes. Additional, at the beginning of the film recording during a satellite contact the read-out processes are started delayed with regard to the clear-write processes which are initiated by the first synchronization pulse, which was derived from the video signals by the digital data processing equipment. According to the random momentary phase between this synchronization pulse, which is also the reset and start function for the address counter controlling the clear-write processes and according to the next following line start signal of the shaft angle encoder, this delay is setting the clear-write mode address counter to a value greater than at least 16384 but maximum 24576 locations indicated by the read-restore mode address counter. By this it will be avoided that possible differences of the rotation speeds of the opto-mechanical scanner and the scanning radiometer on board the satellite within the permissible tolerance, as well as the delay-time effects between the receiver antenna and the orbital satellite lead to overlapping values of read-in or read-out registers whereby the signal series at the output of the core memory would be truncated. Yet it should be mentioned that the read-in and the read-out counters are connected with the same address lines by an appropriate gate logic deciding between clear-write and read-restore mode.

Furthermore, it must be taken in account that every memory location contains two bytes, i.e. it stores two separate picture elements. In principle any synchronization process can happen just after a core memory location had been filled completely by two bytes. But it also may happen that this location had just been occupied by the first byte. Therefore the logic must have regard to these effects by appropriate byte-control-orders to define the beginnings of the line scans.

Recording of the VHRR-data - the revolution period of the film drum must be synchronized to the scan-line period of 150 ms duration. This is guaranteed by a quartz-controlled synchronous motor to an accuracy of at least 0.01 %. The shaft angle encoder which is mounted on the axis of the film drum generates 4096 pulses per revolution which are multiplexed by electronic circuits to divide the periphery of the film drum in 16384 steps in order to image the 15000 samples per scan-line on the applicable 338.75 mm of the film-drum. This requires a resolution of about 44 lines/mm. As a consequence of the described procedure, per revolution of the film drum 16384 clock pulses are available to read out the data from the core memory, but only 15000 bytes are transferred to the opto-mechanical scanner. So, each picture line on the film-drum has a length of 91.5 % of the perimeter of the drum. This is necessary to have no loss of information by stretching the film on the drum. By this method, the earth-scans for both spectral channels are imaged each with a width of 102.35 mm (4 inch) on the film.

Because for the opto-mechanical scanner in the case of the VHRR-system the relations along a scan line are defined, the forward steps of the optical system, that is the line width of the picture printer, must be determined. The needed line width is defined as follows: During the orbital period of the satellite of 116.19 minutes, and a scanning period of the radiometer of 150 ms, 46476 scan lines are realized. This scan-line number covers the meridian with a length of 40008.2 km. With these data we get a scan-path with a width of $D_{VHRR}^+ = 0.861$ km. (In comparison: With the satellite altitude $H = 1464$ km and with an instantaneous detector field of view $\omega = 0.6$ mrad we get for the subsatellite's point a diameter of the resolution element $D_{VHRR} = H \cdot \omega = 0.878$ km.)

This scan-path is to describe corresponding to the imaging scale m , valid along a scan line. This picture scale is calculated according to the usual definition as the relation of the diameter of the picture element (called d_{VHRR}) to the diameter D_{VHRR} of the resolution element

$$m = \frac{d_{\text{VHRR}}}{D_{\text{VHRR}}}$$

By using already known parameters:

$$d_{\text{VHRR}} = 0.032 \text{ mm and } m = 1:21 \text{ } 155 \text{ } 000.$$

With $m \cdot D_{\text{VHRR}} = d_{\text{VHRR}}$ it results for the scan lines the needed line feed of $31.7 \mu\text{m}$ which is adjusted by a synchronous motor with an appropriate gearing. A VHRR-picture recording of the IR- and VIS-channel is demonstrated in Fig. 8.

Recording of the SR-data - the film recording for this system should be available without crucial changes of the electronical data processing equipment and the mechanical system. The same opto-mechanical scanner should be used. To get the same data rate per scan line as above, the sample rate was therefore defined to 12 kHz, thereby being situated within reasonable tolerances.

Because as well the VHRR-system as the SR-system are on board the same satellite and also use the same angle for the earth-scan it is reasonable to define the picture size and the imaging scale as above. So, we get in this case a scan-line feed of $264.2 \mu\text{m}$. Thereby a problem arises: The recording lamp of the opto-mechanical scanner can illuminate maximum an area of $100 \mu\text{m}$ diameter. Therefore the following way was chosen: The data received within the rotation period of the radiometer's scan mirror i.e. 1.25 sec are buffered in the core memory like in the case of the VHRR system. Then each scan line is read out with a speed 8 times as large and is recorded 8 times behind one another onto the film drum. This method requires a revolution time of the film drum of $\frac{1.25}{8}$ sec and furthermore the same line-feed of the optical system like in the case of the VHRR system. To realize this, only the rotation speed of the film drum moving synchronous motor is to reduce about 4 %. Moreover, the field stop for the light source of the film recording is exchanged automatically with the help of relays with respect to a larger line distance of about 4 %.

CONCLUSIONS

In consequence of the excellent synchronization of the rotary motion and of the good quality of the shaft angle encoder the position accuracy of the opto-mechanical scanner is very good. The jitter movement of the picture elements during the recording amounts less than $1/20$ of the pixel distances (pixel distance = sample distance).

Furthermore, the rotation of the drum and the linear forward motion are synchronized so excellent, that the device could be interfaced to a processor for further applications. Especially, the device is also able to scan color films or color prints in 3 spectral channels and to transfer these data to the processor. For such purposes the device additionally was supplemented by a linear measure, whose position statement can be offered to the computer together with the shaft angle encoder position.

REFERENCES

- (1) Schwalb A. "Modified Version of the Improved Tiros Operational Satellite (ITOS D-G) NOAA Technical Memorandum NESS 35"
- (2) Mozer M. "Real-Time Printing of SR- and VHRR-Pictures from the NOAA 3-Type Bücklein R. Weather Satellites and Elimination of Signal Propagation Delay Effects between the Satellite and the Ground Station". Fourth Annual Remote Sensing of Earth Resources Conference Tullahoma, Tennessee, 1975

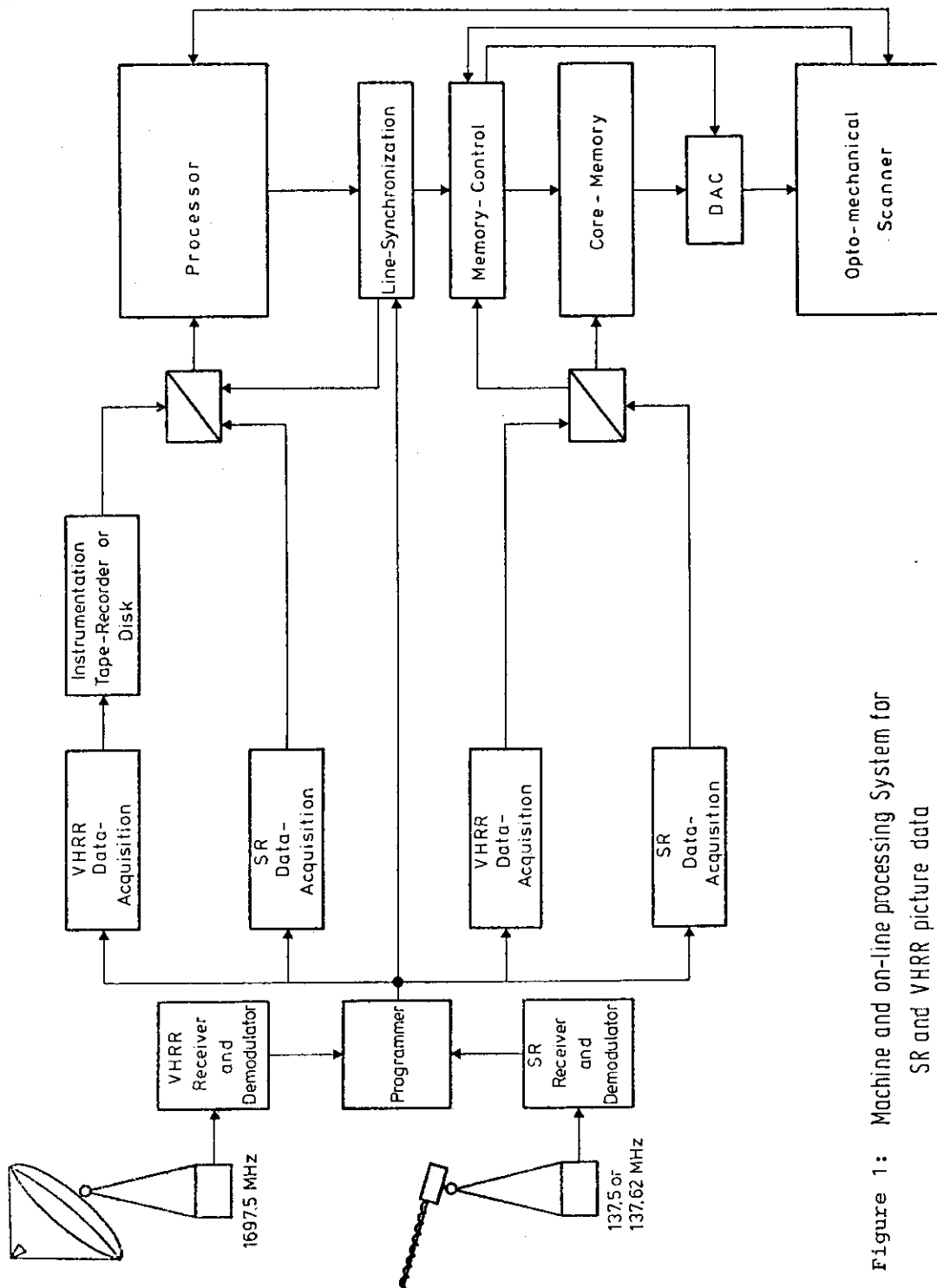

Figure 1: Machine and on-line processing System for SR and VHRR picture data

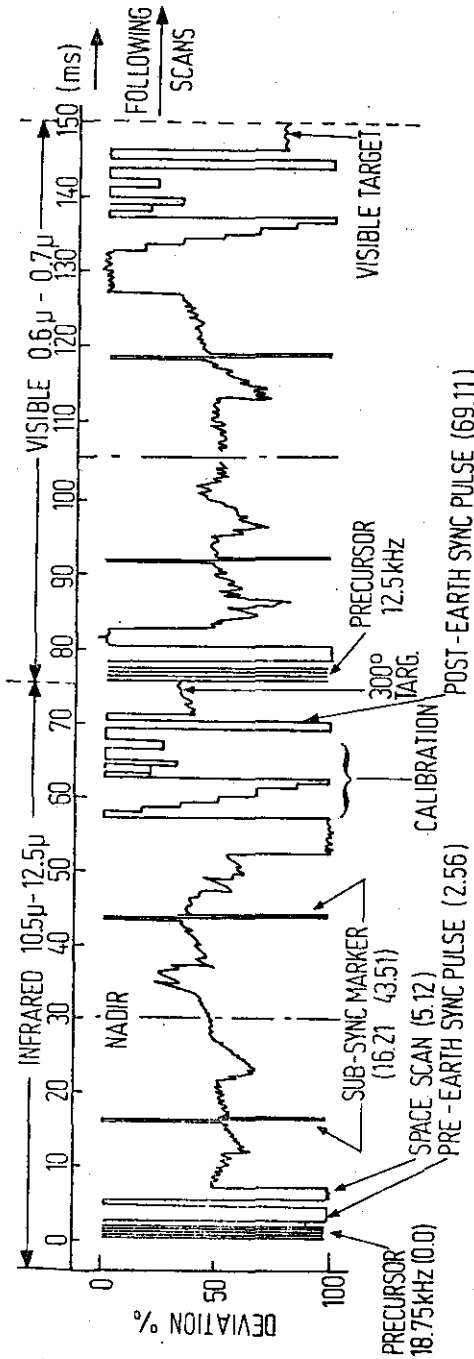

Fig. 2: VHR SENSOR - IR AND VISIBLE SIGNAL CHARACTERISTICS

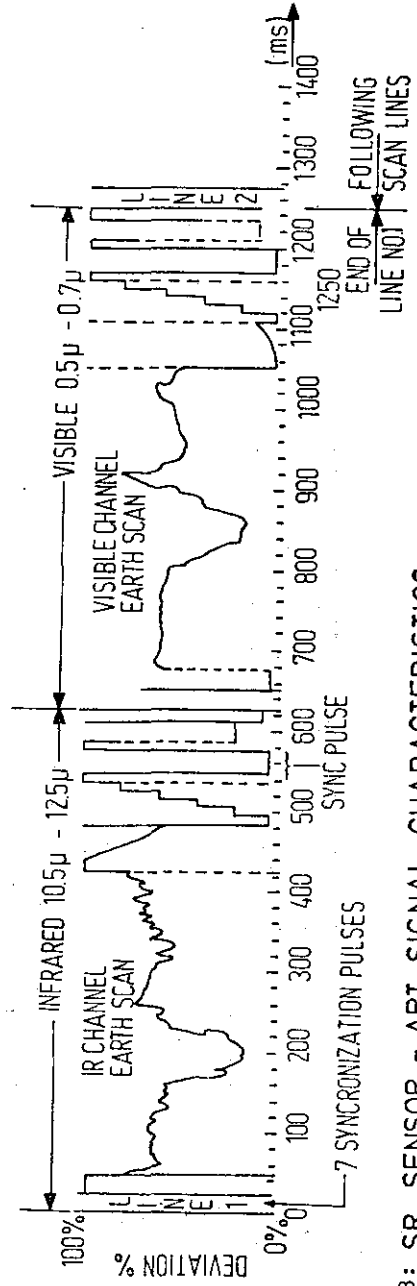

Fig. 3: SR SENSOR - APT SIGNAL CHARACTERISTICS

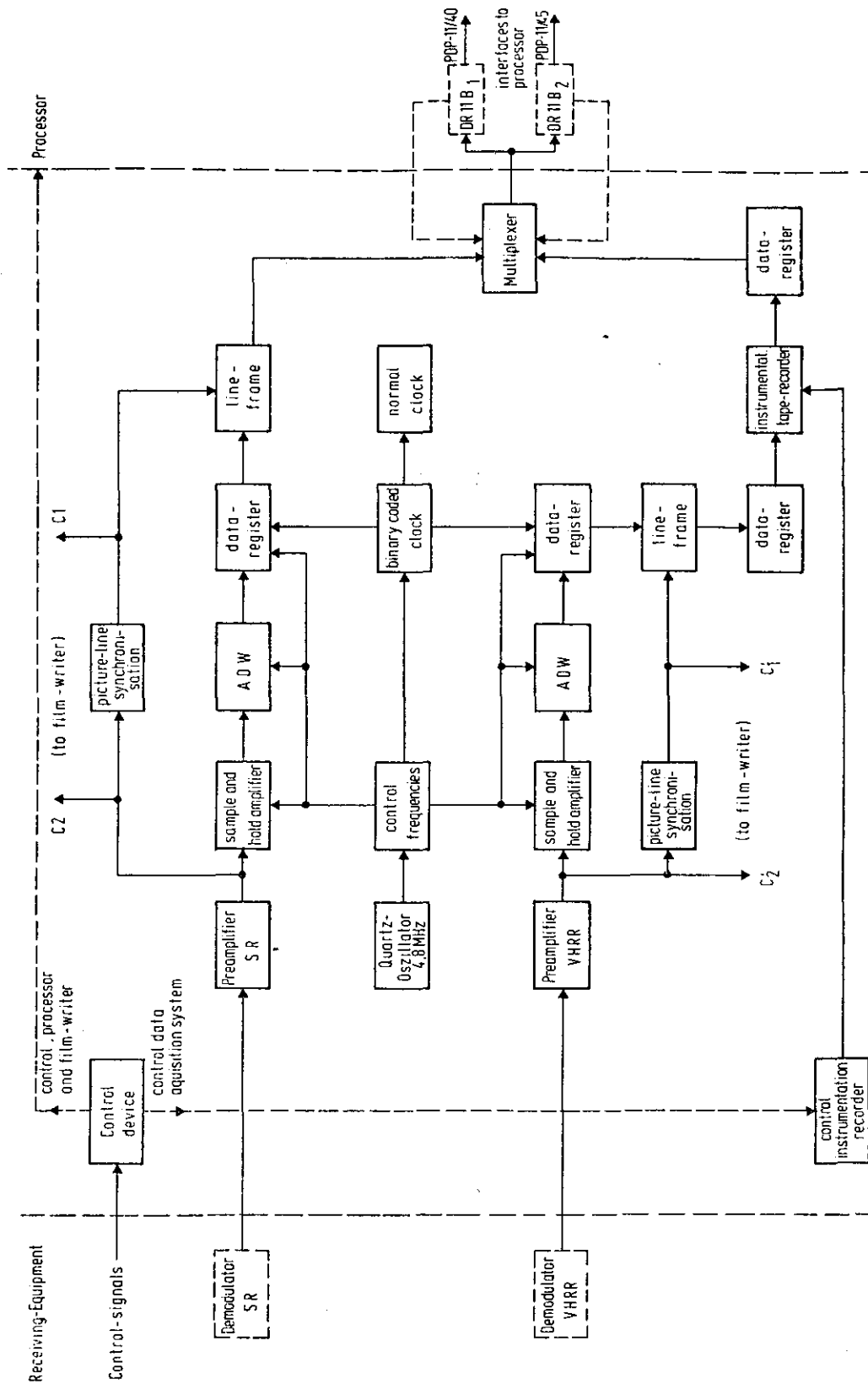

Fig. 4: Picture-data acquisition-system

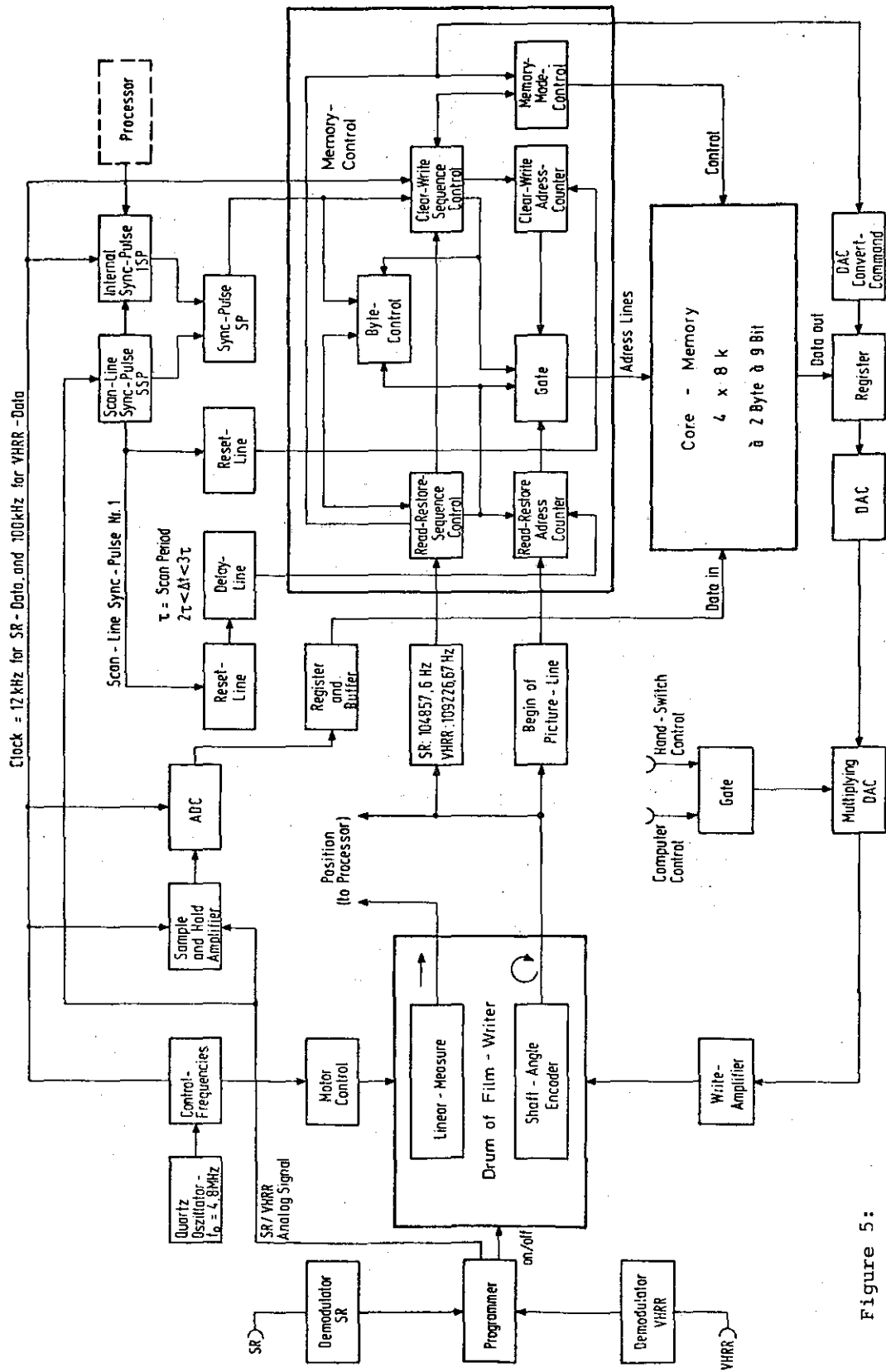

Figure 5: Block - Diagram of Data Acquisition and On-Line Writing of SR and VHRR Picture Data

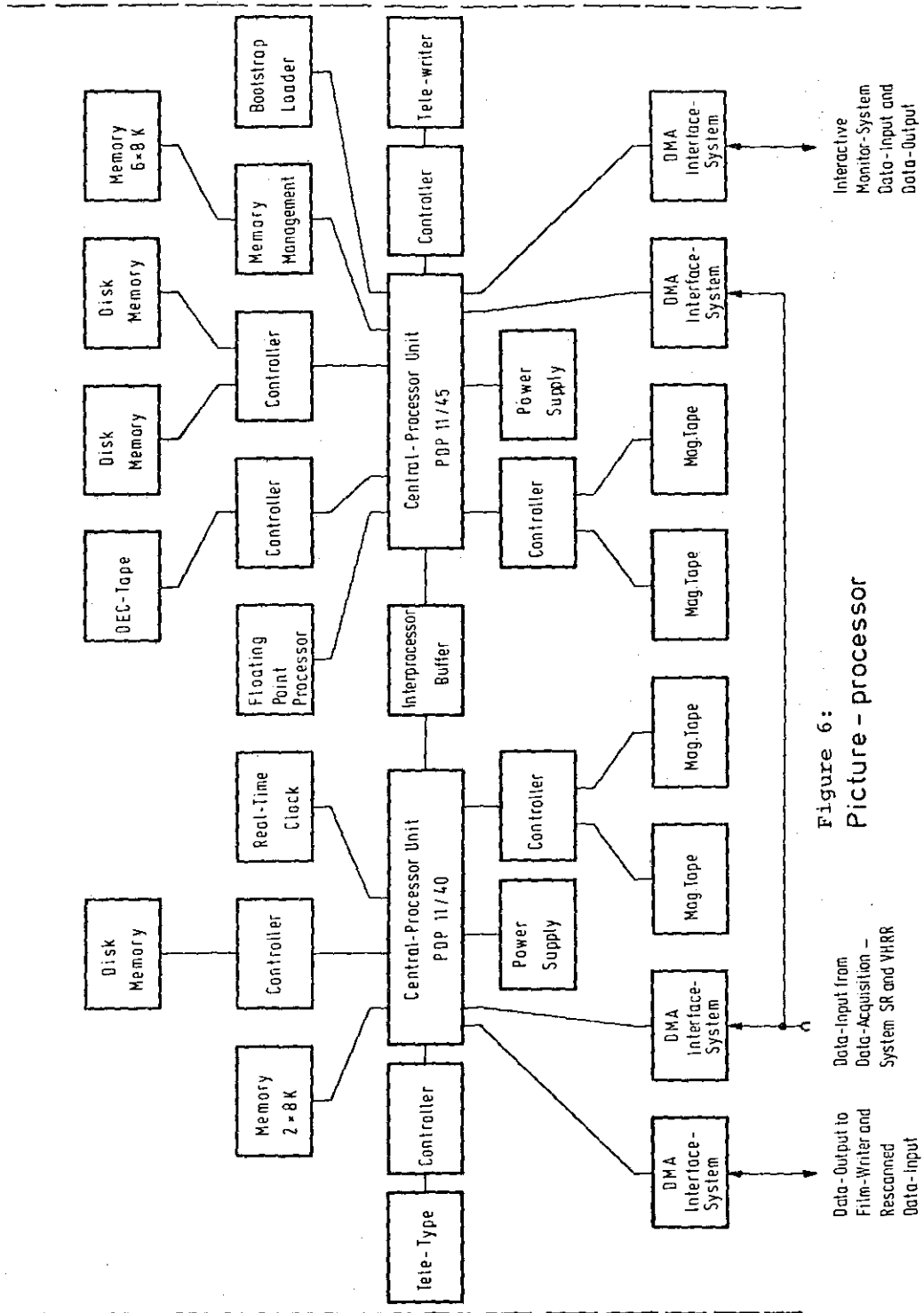
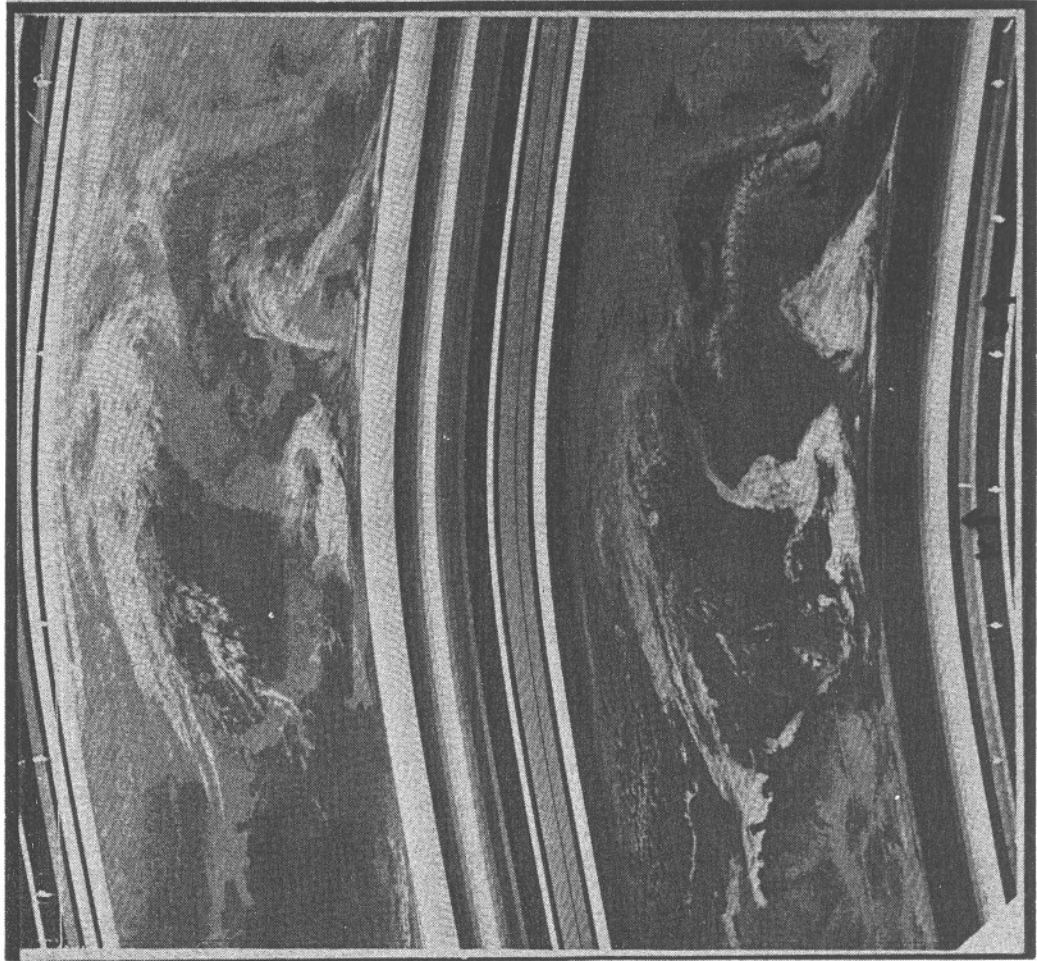

Figure 6:
Picture - processor



Infrared

Visible

Figure 7: Real-time recording by a modified APT-picture printer of VHRR-pictures received from the NOAA 4 weather satellite showing Western-Europe.

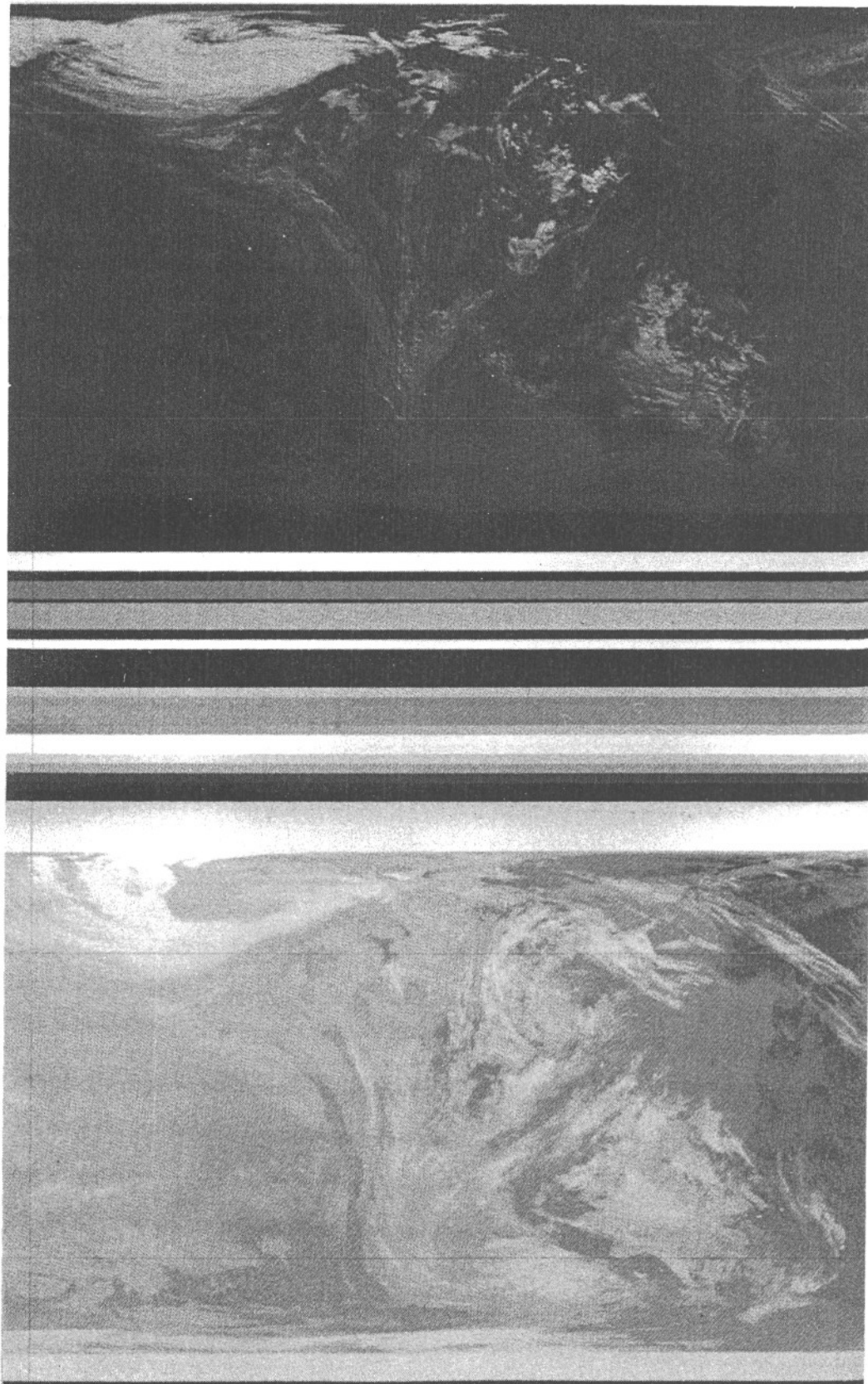

Visible

Infrared

Figure 8: Real-time recording by the Chromagraph of VHRR-pictures received from the NOAA 4 weather satellite, showing the weather conditions over Central Europe. The North African coast can be recognized on the bottom.